

PACCAR Level 4 Demonstrator



CAMERAS

LIDAR

RADAR

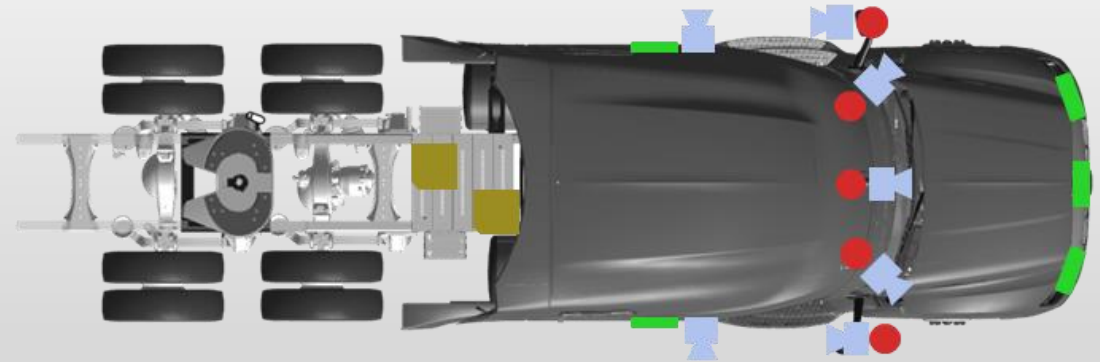

Hybridization / Electrification



DAF XF/CF
Parallel Hybrid
Electric Range 20 Miles



DAF CF Electric
Electric Range 75 Miles



Kenworth Hybrid Electric
Electric Range 250 Miles



Peterbilt Electric Refuse
Electric Range 80 Miles



Peterbilt Electric Port
Electric Range 150 Miles



Kenworth Hydrogen Port
Electric Range 150 Miles

Trucks of the Future

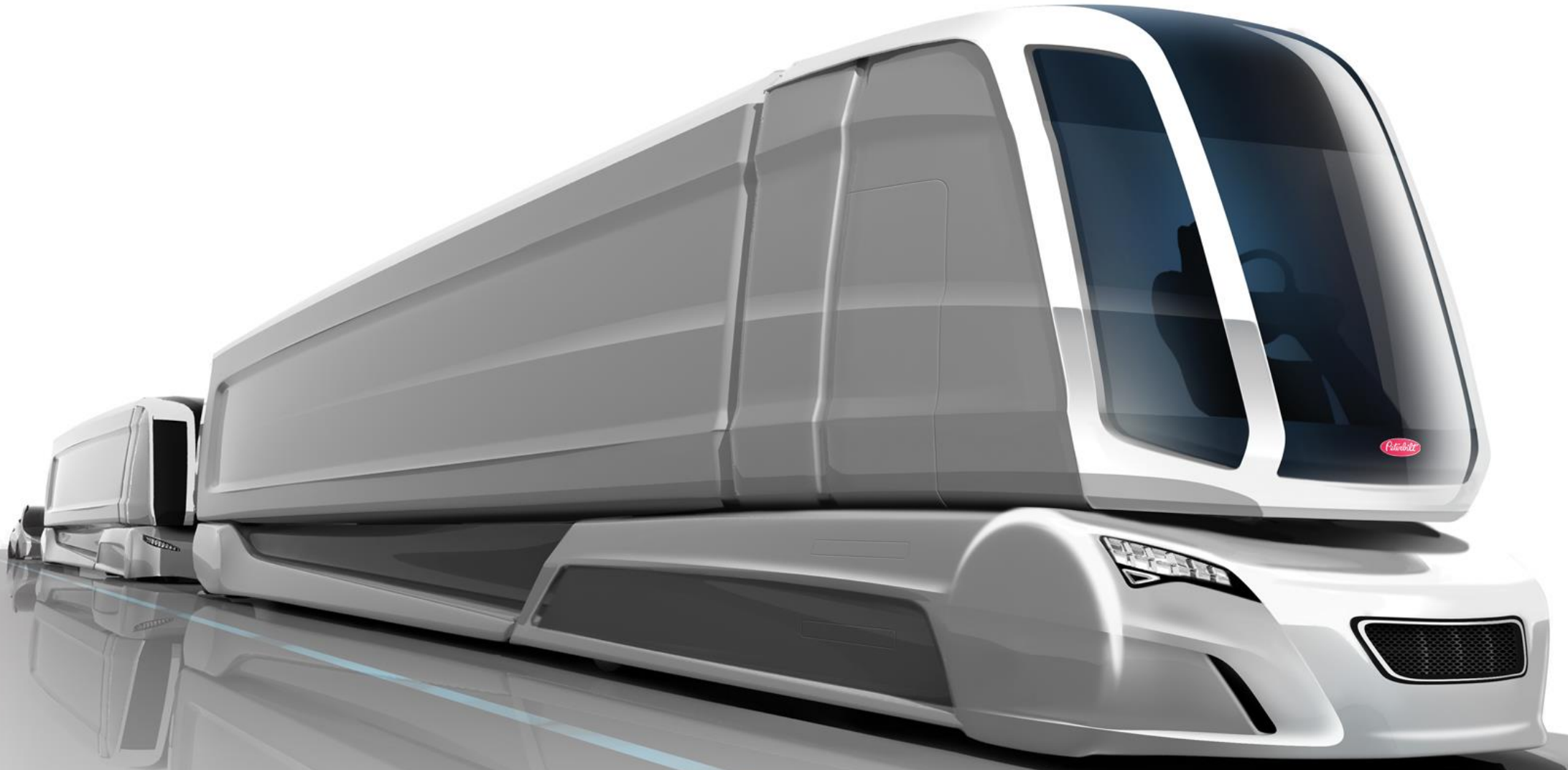

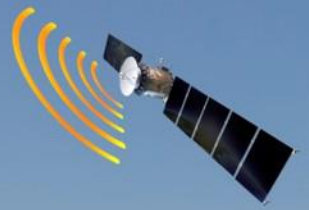
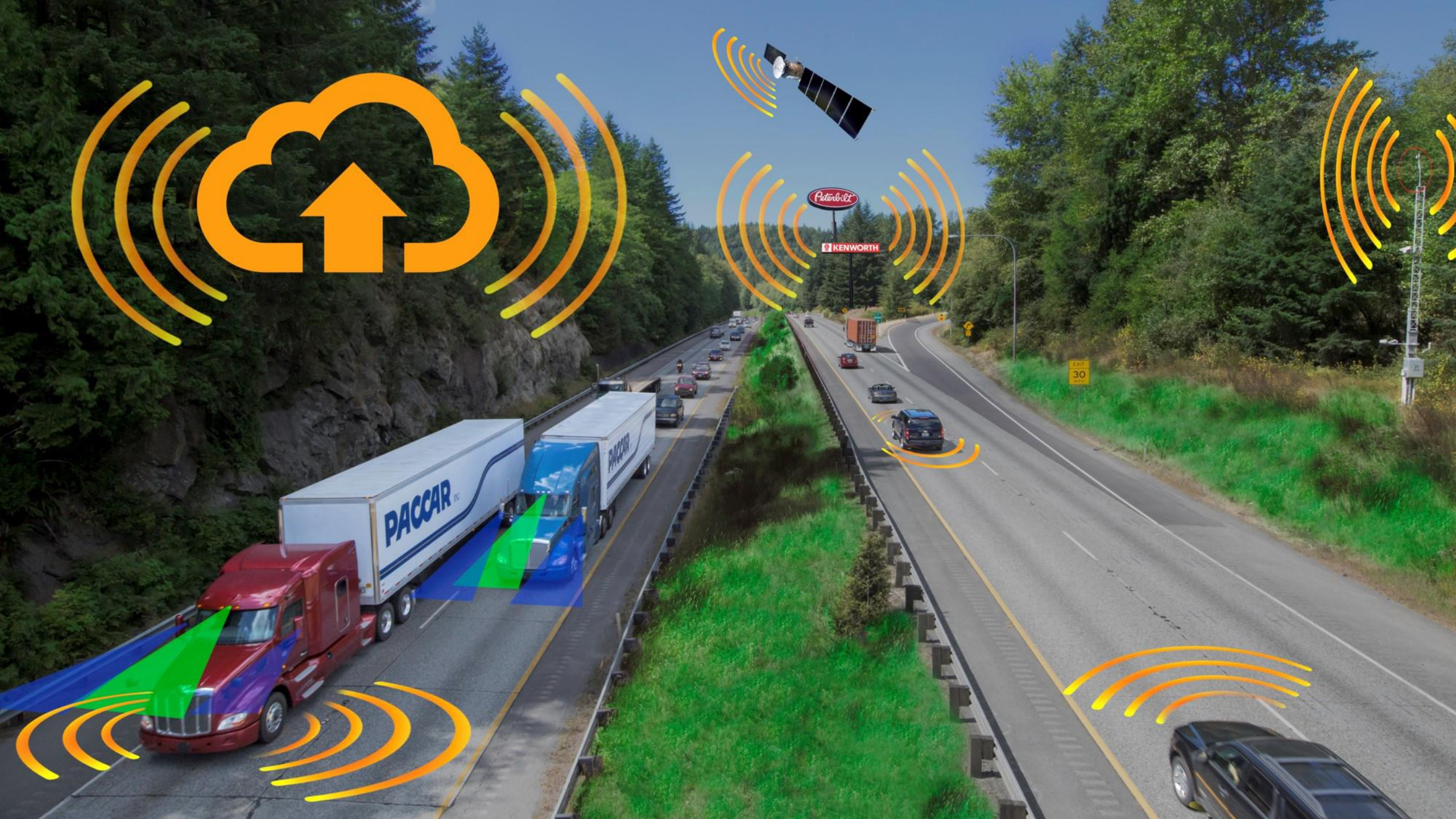

Peterbilt

KENWORTH

EXIT
30

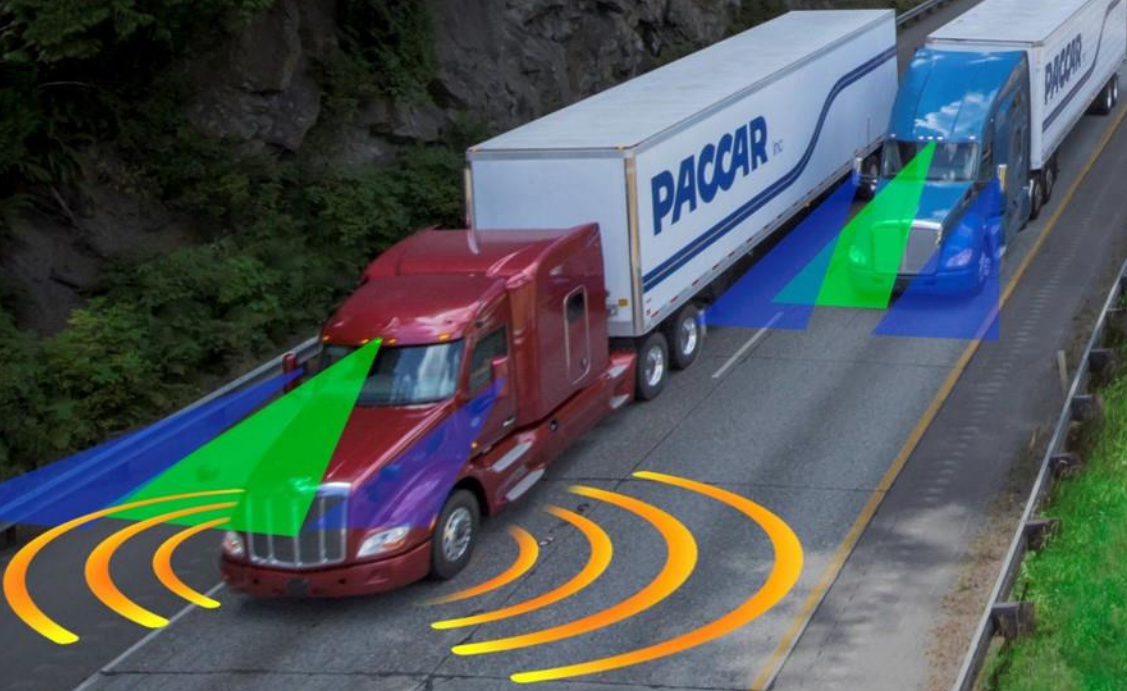

PACCAR Connectivity Roadmap

2018



2019



2020



2021+



Business Intelligence

- Data Analytics
- Data Security
- Over the Air Updates

Predictive Maintenance

- Mobile Service Techs
- Increased Uptime

Advanced Fleet Management

- Fleet Dashboard
- Route/Equipment Optimization

Autonomy

- Detailed Dynamic Mapping
- Vehicle-to-Vehicle

PACCAR ADAS Roadmap

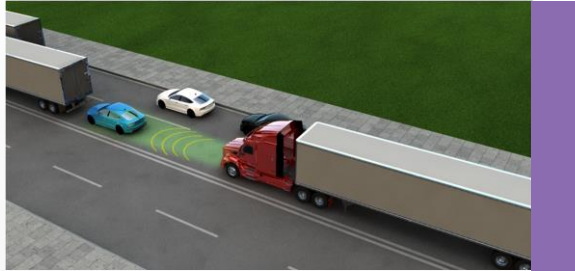

Traffic Stop & Go

2018

2017



Auto Emergency Braking

2019

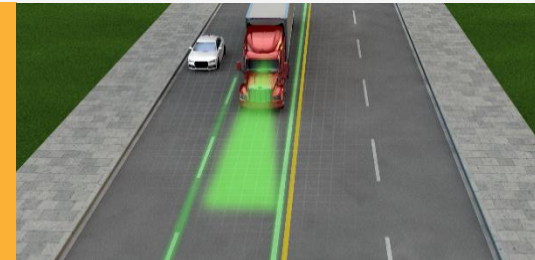

Lane Keeping



Platooning

2020



Object Detection

2021



Driver Monitoring

Emerging Autonomous Applications

Social Acceptance and Economic Feasibility

Platooning



Closed Course Autonomy



On-Highway Autonomy



Urban Autonomy



Sustainability

CO₂ Reduction



Air Quality

